

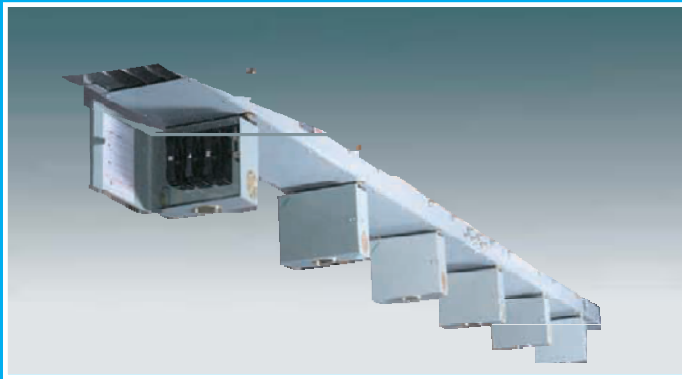

GE ENERGY

Overhead Busbar System



Why an Overhead Busbar System?

G E Power Controls overhead busbar system provides the most efficient and optimum distribution of medium voltage power in industries where concepts of planned production and scientific factory layouts are applied, ensuring complete safety.

With an increasing need to alter shop layouts and changes in production patterns to meet the ever-demanding market, overhead busbars provide the necessary flexibility to make such changes quickly, with minimum power shutdown, utilising the existing cables, conduits and fittings. This system provides for installation outputs that can be maintained at peak levels. Thus, in this context, the need for an overhead busbar system in industries, becomes a priority automatically.

Many years of operating experience has proved that the G E Power Controls Ltd., over head busbar system gives troublefree service throughout its life, with practically no maintenance.

Ratings

The system is available in TPN arrangement with ratings of 200A and 400A for an operational voltage of up to 500AC.

Salient Features

Maximum flexibility - With plug-in points provided at inter vals of 60.96 cm. along with busbars.

Complete safety - Fully insulated plug-in points ensure safety for operating and maintenance personnel.

No shut-down - Plug-in boxes can be plugged into live busbars quickly and safely.

Easy extensions - Ratings of busbars and numerous plug-in points ensure ample accommodation for future loads. Busbars can be extended easily by coupling with new lengths.

Guaranteed protection - HBC fuse-links at all plug-in points ensure positive and reliable short-circuit protection.

Durability and long life exceptionally robust and rigid construction. All ferrous materials are rust-proofed before priming and finishing.

Construction

The overhead busbar system consists of a robust busbar chamber, flanges of which are connected together with a tie-bolt. The sheet-steel parts are rust-proofed with anticorrosive chemicals prior to the application of uniconat stoved enamel finish. The busbar run through this chamber supported by fire-retardant phenolic moulds, which also serve as plug-in points.

The overhead busbars are supplied in standard lengths of 3.65 mtrs. (200A) and 2.44 mtrs (400A). The busbars are made of high conductivity aluminium complying to specification 63401 T6 of IS 5082-1981. The busbars are completely shrouded in PVC sleeves throughout their length, except at the plug-in points to enable connection of outgoing circuits by means of plug-in boxes.

Bus bar Couplings

Busbar lengths can be coupled mechanically and any length of run in multiples of the standard length may be thus achieved. Electrical contact is achieved by bolting together overlapping ends of the busbars and securing the screws with locking plates. Detachable blank-end-covers are available for enclosing the free ends of the busbar run.

A connector-assembly is supplied loose, with each length for coupling two length, and comprises-

- Rubber locating ring
- Busbar insulating tube
- Connector insulating tube

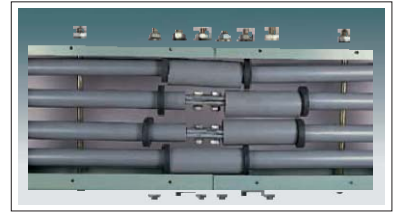

Two sections of 200 Amps. busbars coupled together.

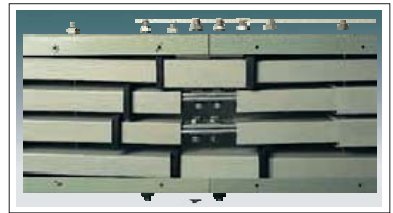

Two sections of 400 Amps. busbars coupled together.

Plug-in Boxes 32A, 63A & 100A

These are compact sheet-steel boxes with hinged-doors housing the fuse-holders, which are solidly connected to high conductivity copper clip-on contacts reinforced by spring steel strips. These clip-on contacts plug directly on to the busbars at the plug-in points. For additional safety, two earth-pins are located at the two ends of these boxes. While inserting these boxes into the plug-in points, the earth pins engage first in the special earth bushes provided on the underside of the busbar chamber before the main contacts make. While withdrawing these boxes, the earth connection is maintained even after the main contacts are isolated.

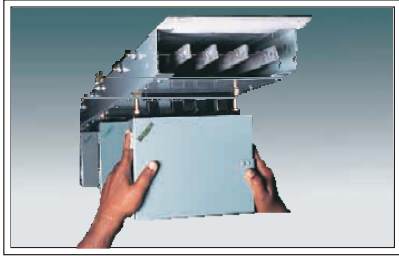
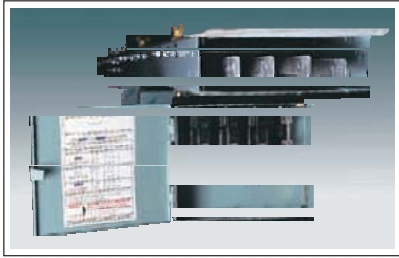

Diagram showing a busbar layout for small factories

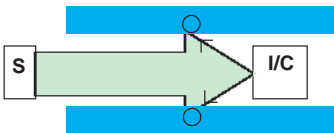
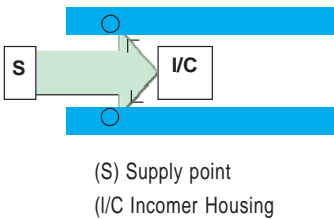

Diagram showing busbars being fed from the centre where load is evenly distributed. Centre - feeding effectively doubles the current carrying capacity of the system.

Method of Securing

The plug-in boxes inserted into the plug-in points are fastened by wing-nuts provided. For plug-in boxes used in 400A rating extended wing-nuts are to be used for negotiating greater depth.

Important

While ordering for plug-in boxes suitable for 400A overhead busbars, please specify the busbar rating so that the plug-in boxes can be supplied with extended wing-nuts.

Incoming Supply

The incoming supply connections for the overhead busbars are made through a connector housing. This housing is mounted preferably on the top of the chamber at intervals of 2 feet from either end, or in the centre. It consists of a steel enclosure with interconnections for connections for connecting to the main busbar.

Installation

The usual method of installation is to lay the busbar system on roof trusses, but if required can be suspended from the roof using brackets to suit site conditions. This busbar system can also be installed in factories equipped with overhead cranes, by mounting it on supporting stanchions below the gantry level or on supports specially provided to carry them 2 metres above ground level. The unsupported span should not exceed 2 metres.

Connection to plug-in boxes are recommended, using conduit pipe to conduit glands supplied with PIB.

If multi-core PVC cables are used, care should be taken at the site to support the cable, to avoid additional strain on fuse-fitting contact with cable connection, thus preventing failure of contacts.

While connecting aluminium cables directly to fuse fitting contacts, care should be taken as mentioned in instruction sheet supplied with PIB.

Blank end-covers should be ordered and provided at either end of the length to avoid entry of vermin.

Tests

Each length of overhead busbar undergoes the following tests before despatch:

- a. A high voltage insulation withstand test for 2 kV for 1 minute.
- b. An earth impedance test.

Short Circuit Protection

The rapid operation and high breaking capacity of G E Power Controls fuselinks enable them to meet the need for reliable short circuit 'back up' protection of motor control gear. Correctly chosen fuselinks will discriminate with the overcurrent trip device, permitting it to operate on faults within its capacity.

For normal industrial installation fuselinks may be used from the fuse rating as given in the table, which are based on average conditions for direct online or assisted start motors where special drives involve high torque motors, frequent start duties or extended starting times, fuse-links of higher rating may be required.

Dimensions are in millimetres unless otherwise specified

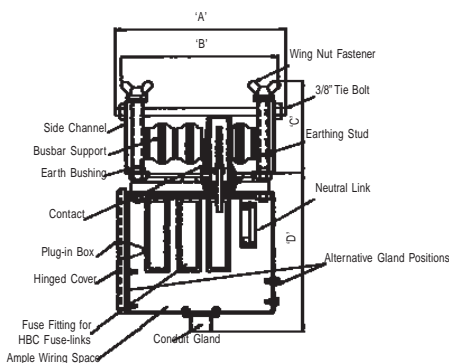

Ref.	Description	A	B	C	Size of conduit gland in plug-in box (Both TP & TPN)
		For T.P.N			
1	200/300A. OHBB WITH 32 & 63 PLUG-IN BOX	251	219	98	FOR 1 1/4\" CONDUIT
2	200/300 A. OHBB WITH 100A PLUG-IN BOX	251	219	98	FOR 2\" CONDUIT
3	400 A. OHBB WITH 32 & 63 PLUG-IN BOX.	251	219	133	FOR 1 1/4\" CONDUIT
4	400 A. OHBB WITH 100 A. PLUG-IN BOX	251	219	133	FOR 2\" CONDUIT

Technical Data

Overhead busbars

Rating	Overall Dim in mm	No. of plug-in points	Weight in Kg.
200A	3658x248x76	6	46
400A	2440x248x108	4	40

Plug - in box

Rating	Code	Associated fuse link
32A	RRF 303 - N4	TIS, TSA
63A	RRF 603 - N4	TSA, TSS
100A	RRR 1003 - N4	TSD

Recommended fuse ratings for motor starting 400 Volts 3-phase

Motor		H.B.C. Fuse-link Rating Amps.	
Horse Power	Full load Amp.	D.O.L Start	Assisted Start
0.5	1.5	4	2
1	2	6	2
2	3.5	15	6
3	5	20	10
4	6.5	20	15
5	8	25	15
7.5	12	30	20
10	15	40	25
12.5	18	50	25
15	21	60	30
20	28	80	40
25	35	100	50
30	41	100	60
35	48	-	80
40	55	-	80
45	62	-	100
50	69	-	100

GE Energy

GE India Industrial Private Limited
Plot No. 42/1 & 45/14
Electronic City - Phase II
Bangalore - 560100
Ph: (080) 41113000
Fax: (080) 28528469/552